



ESYBOX MAX

PRODUCT INFORMATION |

A NEW ERA



FEATURES



VFD

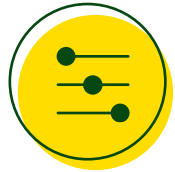

Expansion
Vessel



Pump

Sensors



NRV



ALL INTEGRATED

PERFORMANCE

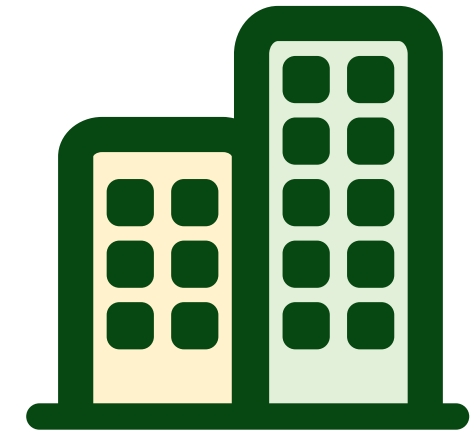
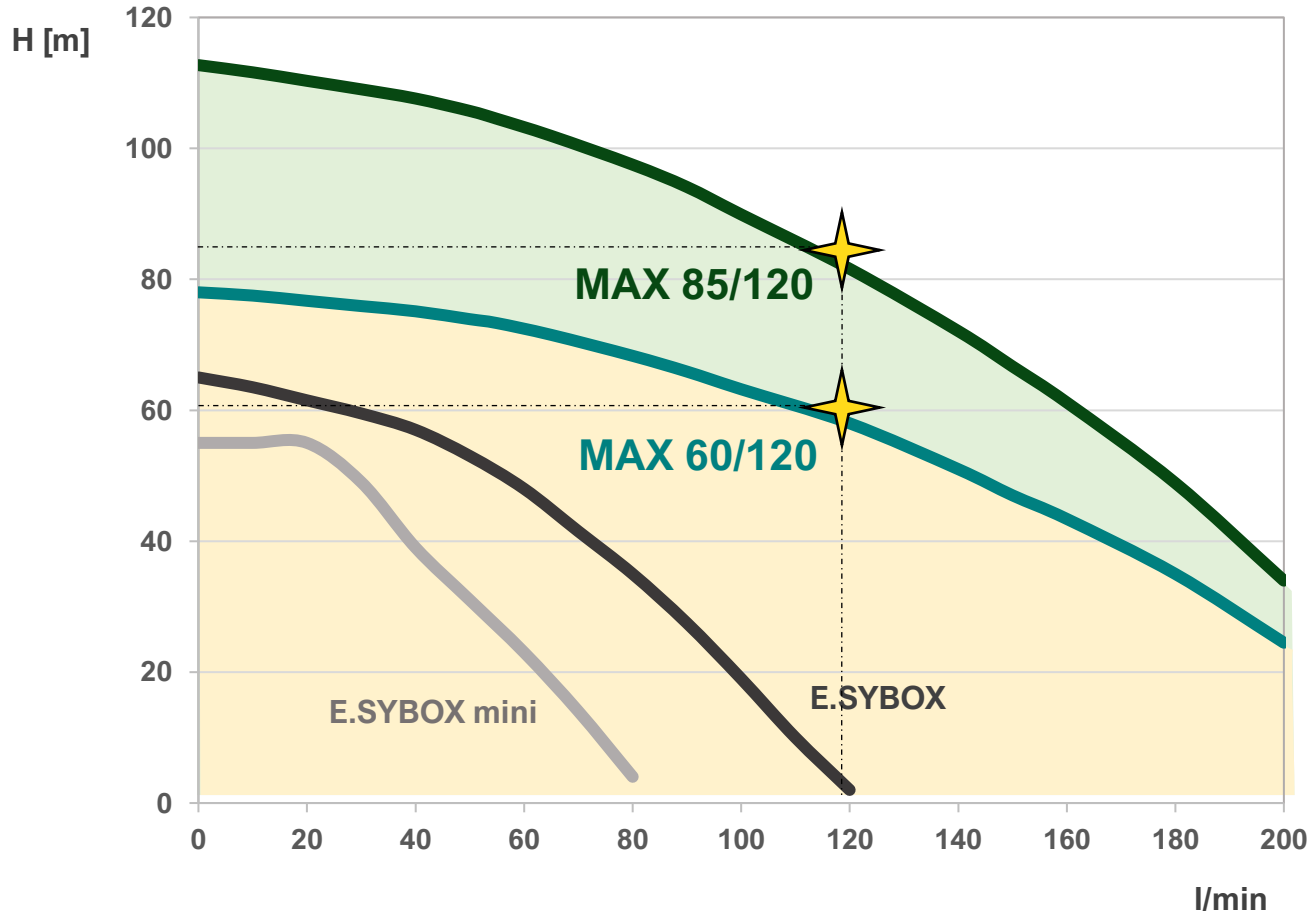

60/120 M/T

Up to 8 floors
and 20 apartments

85/120 T

Up to 14 floors and
20 apartments

MODULARITY



2



3



2+2



PERFORMANCE

85/120 T
max head = 113 m

60/120 M/T
max head = 80 m

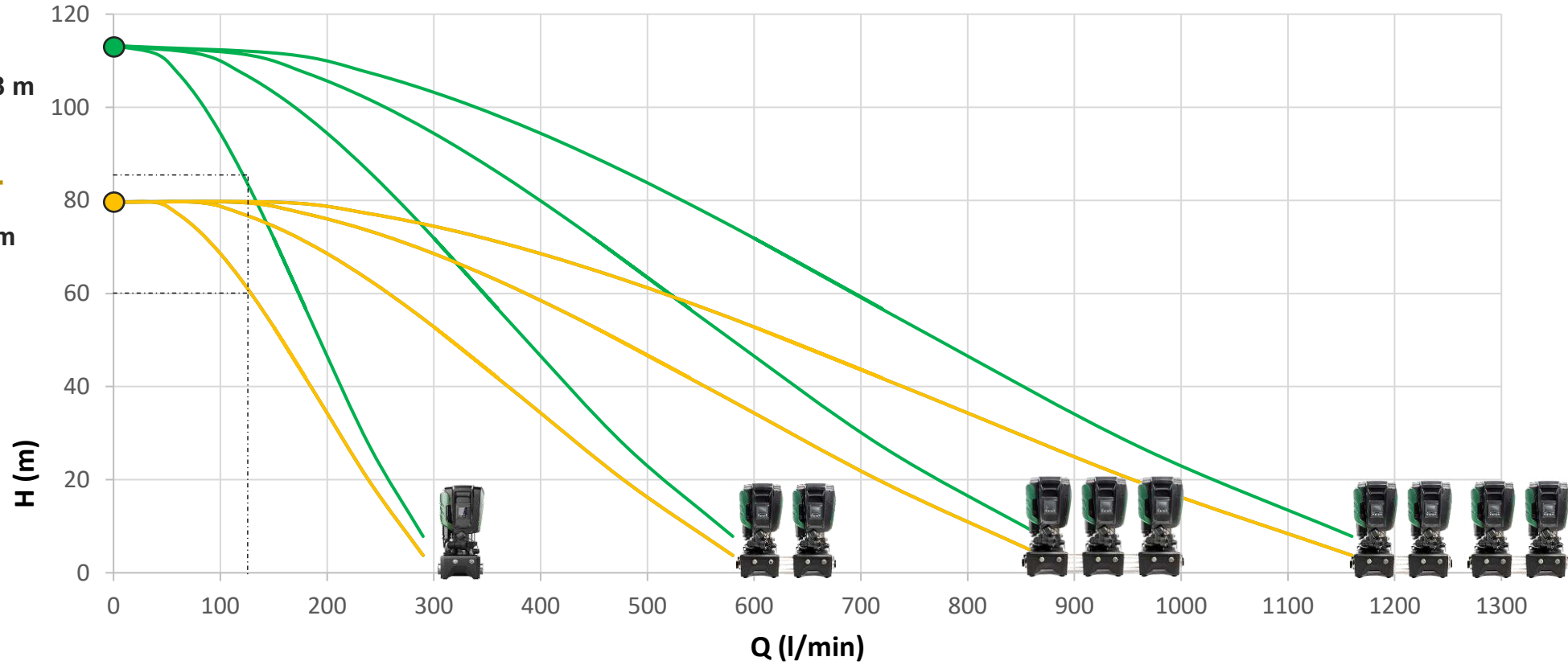



Comfort Energy Saving

KVCE vs ESYBOX MAX 85/120

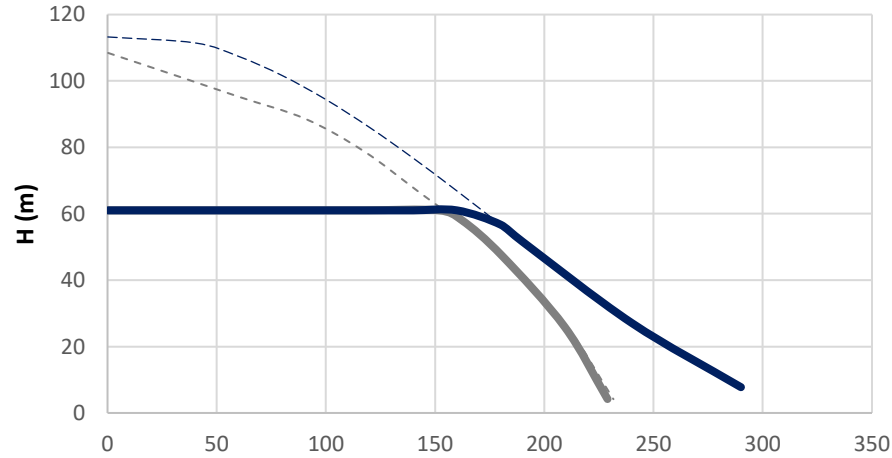

On/Off
Pump

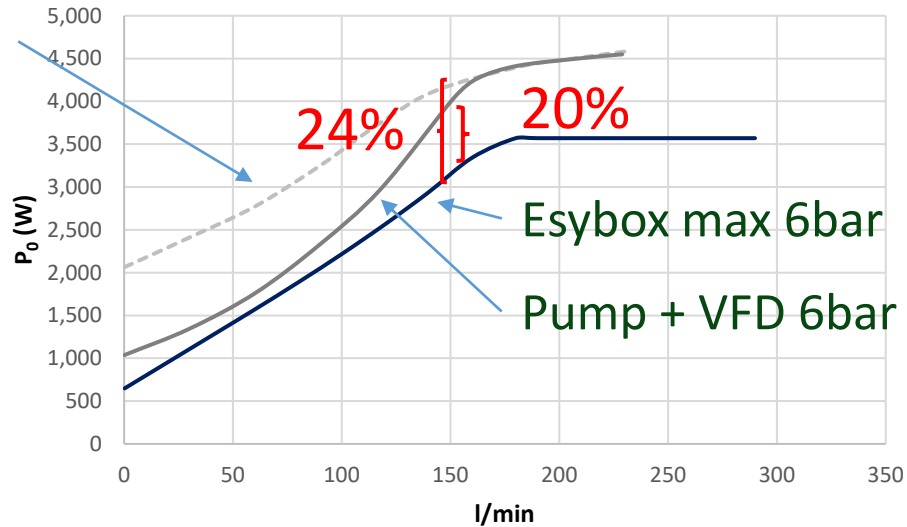

**PERMANENT
MAGNET
MOTOR**



**HIGH
EFFICIENCY
HYDRAULICS**

energy saving	vs Pump+ VFD	Vs On/Off Pump
DAILY	2.8 kWh	12.2 kWh
ANNUAL	1.038 kWh	4.461 kWh

 **Comfort
Silence**



**WATER
COOLED
MOTOR**



ESYBOX MAX

A little more than a **conversation**

63 dB (50 l/min @ 6 bar)

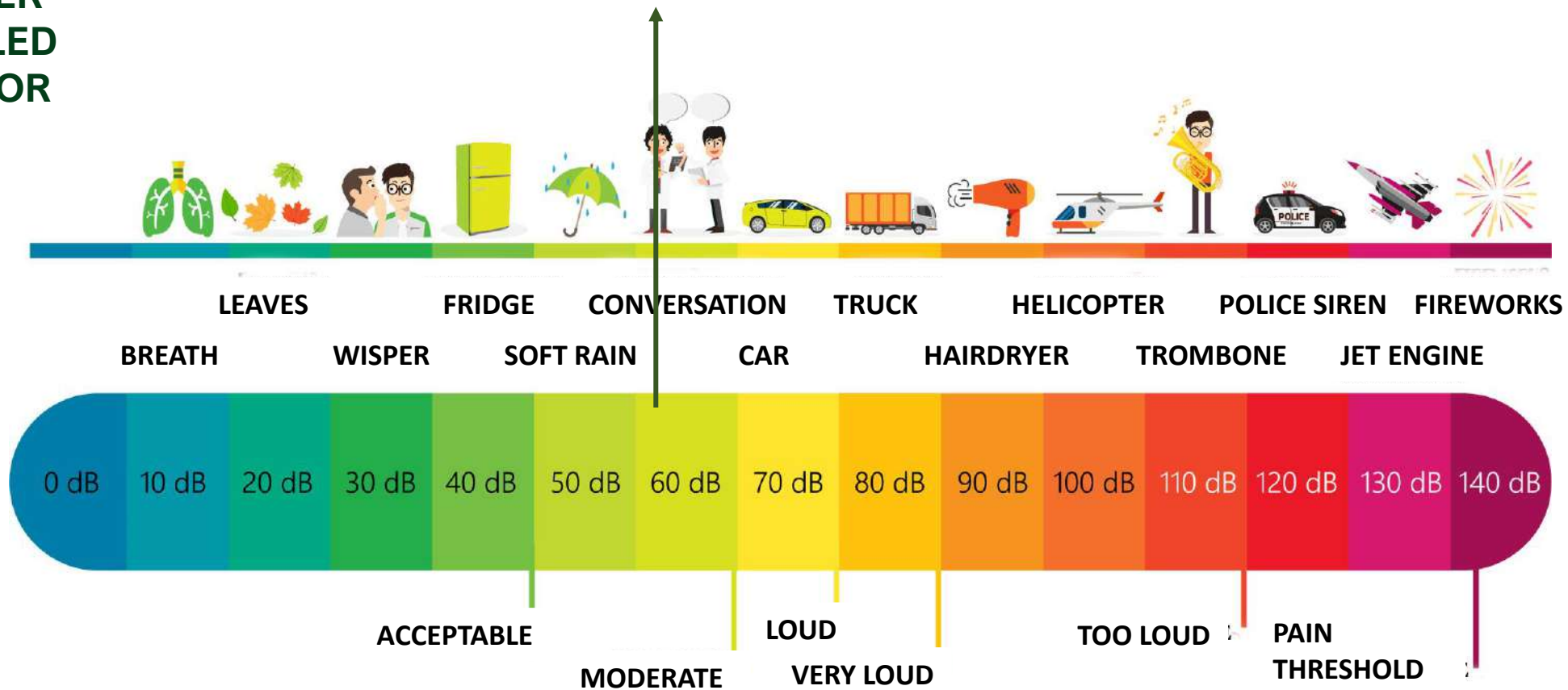

ENGINEER



Modular

WHOLESALER



Space-saving

INSTALLER



**Lightweight, on
site assembly**

MAINTAINER



Connected

CUSTOMER



Adjustable

ENVIRONMENT



**Recycled
materials**



SIMPLER MAINTAINANCE

Modular and functional construction. The modular components of the pump make it easier to perform maintenance. The parts can be removed, repaired and replaced separately, simplifying the resolution of any issues and reducing maintenance costs.

EASY TO STORE



VS



BEFORE

AFTER

OUR PROPOSAL



TRANSPORTATION



HANDLING



Size



375 x 750 x 375 mm

Weight



31 Kg

Packaging

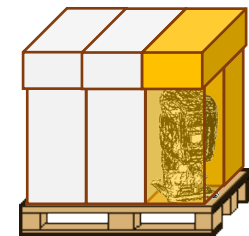

6 PCs/pallet



esybox DIVER



esybox MAX

DAB[®]

WATER • TECHNOLOGY

Esybox Max is an integrated pumping system for water pressurization in commercial building service. It is composed of modular elements that allow different configurations: single, double, triple or quadruple system are possible, to cover the needs of medium/large condominiums and high buildings. The innovative support base of the pumping unit and the wireless communication between the pumps make it possible to assemble the unit directly at the installation site even by one person.

MAC Design, DAB Pumps, style, innovation, quality and technology: right ingredients to win the IF design award in 2021!



EACH UNIT CONSISTS OF THE HYDRAULIC CONNECTION BASE AND THE PUMPING UNIT WHICH INCLUDES:

- ELECTRONIC VERTICAL MULTI-IMPELLER PUMP
- DISPLAY
- WI-FI MODULE
- PRESSURE SENSORS
- NON-RETURN VALVE ON DELIVERY
- EXPANSION TANK

CONCEPT DESIGN Sketches

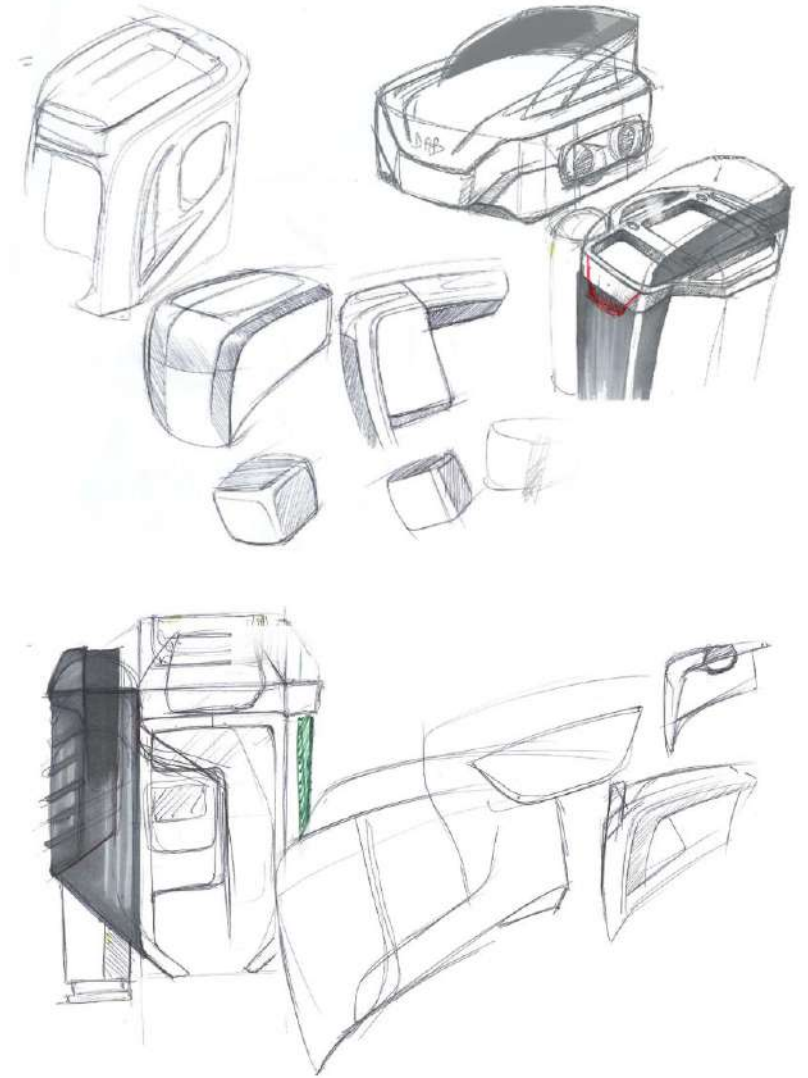

CONCEPT DESIGN
Moodboard Inspiration

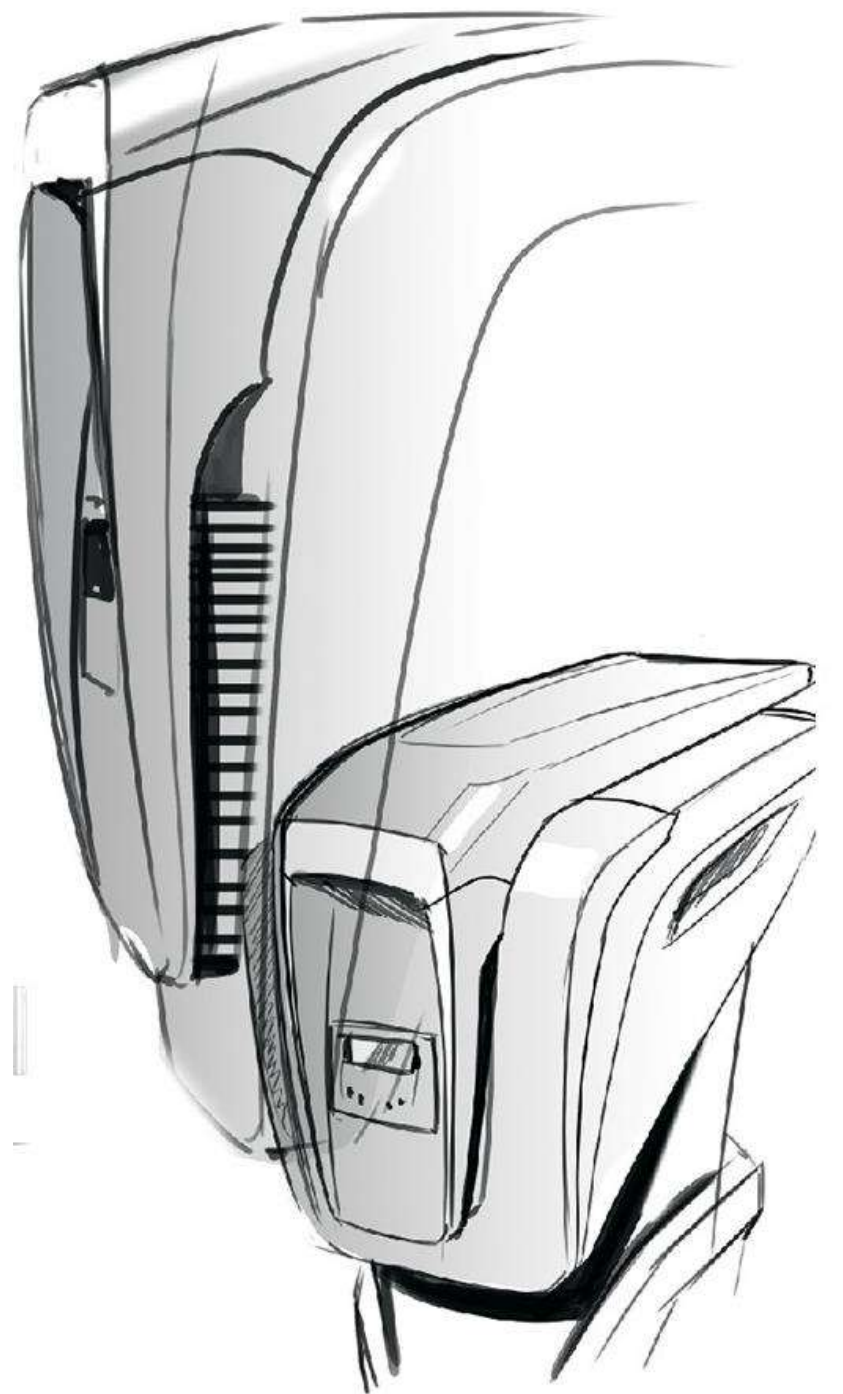
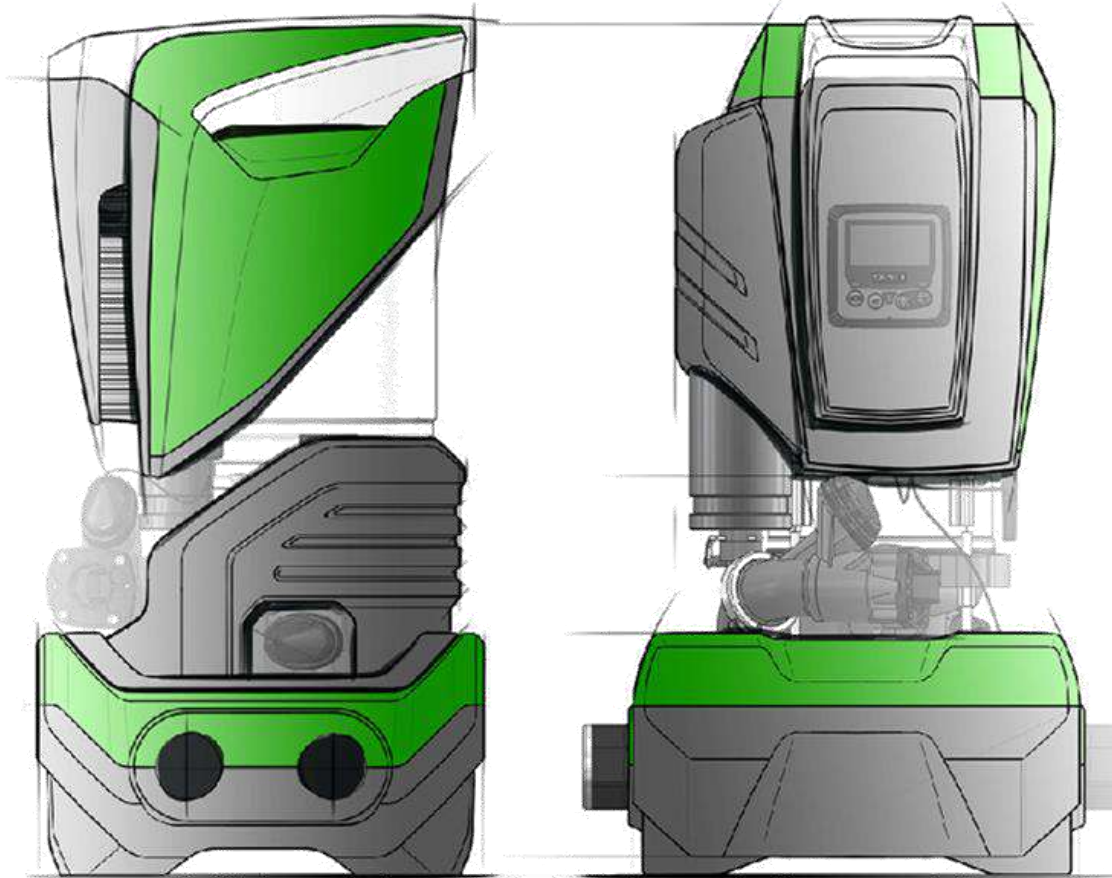

TECHNICAL FEATURES

TECHNICAL SHEET

Text	Parameter		ESYBOX MAX 60/120M	ESYBOX MAX 60/120T	ESYBOX MAX 85/120T
ELECTRIC POWER SUPPLY	Voltage		208-240	380/480	380/480
	Phases		1	3	3
	Frequency		50/60		
	Maximum current		11,8 A	4,2 A	5,5 A
	Maximum power		2,68 KW	2,65 KW	3,5 KW
	Leakage current to earth		<2 mA	<4 mA	<4 mA
CONSTRUCTION CHARACTERISTICS	Overall dimensions		766x375x384		
	Empty weight (excluding packaging)	PUMP	29	29	30
		ESYDOCK		9	
		2 ESYDOCK		18	
		3 ESYDOCK		27	
	Protection class		IPX5		
Motor insulation class		F			
HYDRAULIC PERFORMANCE	Maximum head		7,7bar	7,7bar	10bar
	Maximum pressure at intake		5 bar		
	Maximum working pressure (PN)		12 bar		
	Maximum flow rate		300 l/min		

SUCTION CAPABILITY

2

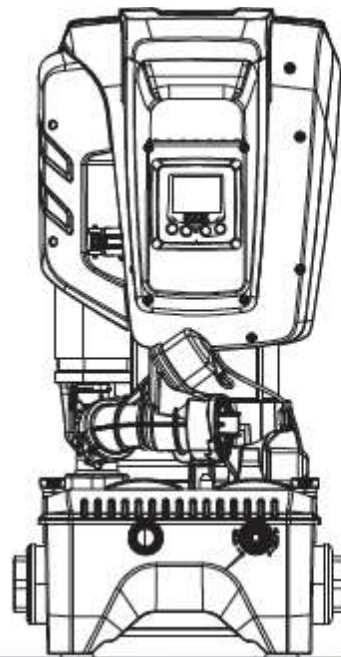

Max 55°C - 131°F



0°C + 50°C
32°F + 122°F

OUTDOOR INSTALLATION



PRESSURE TANK

5

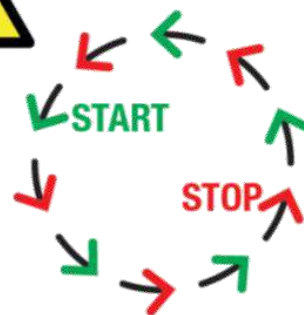
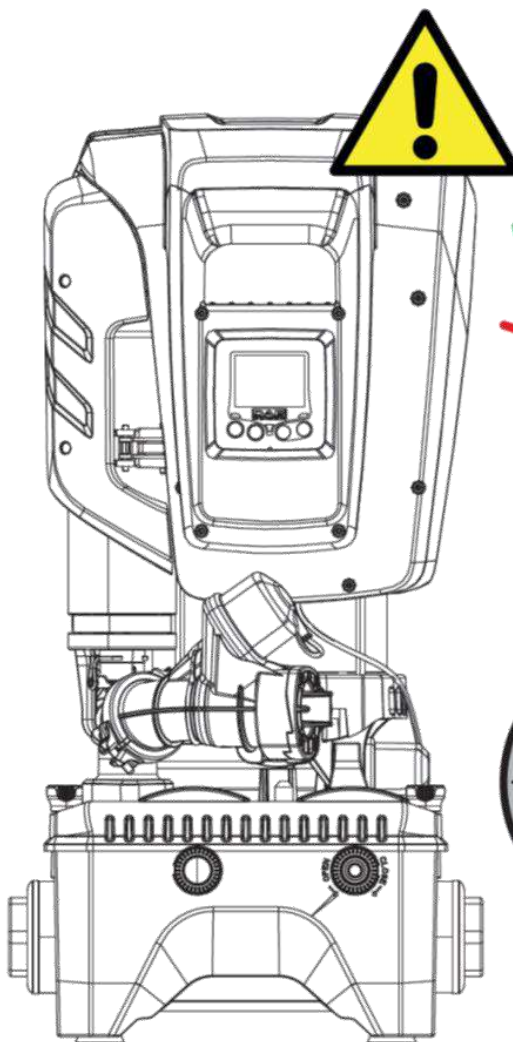
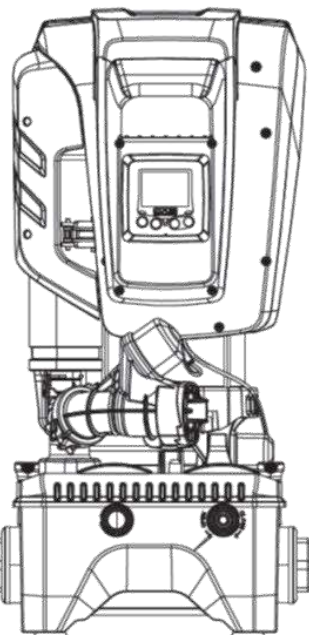

**MAX 30
START**

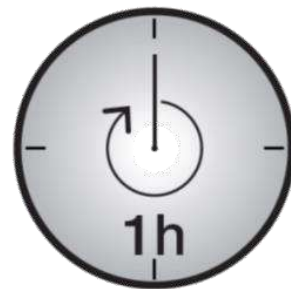

EXPANSION VESSEL

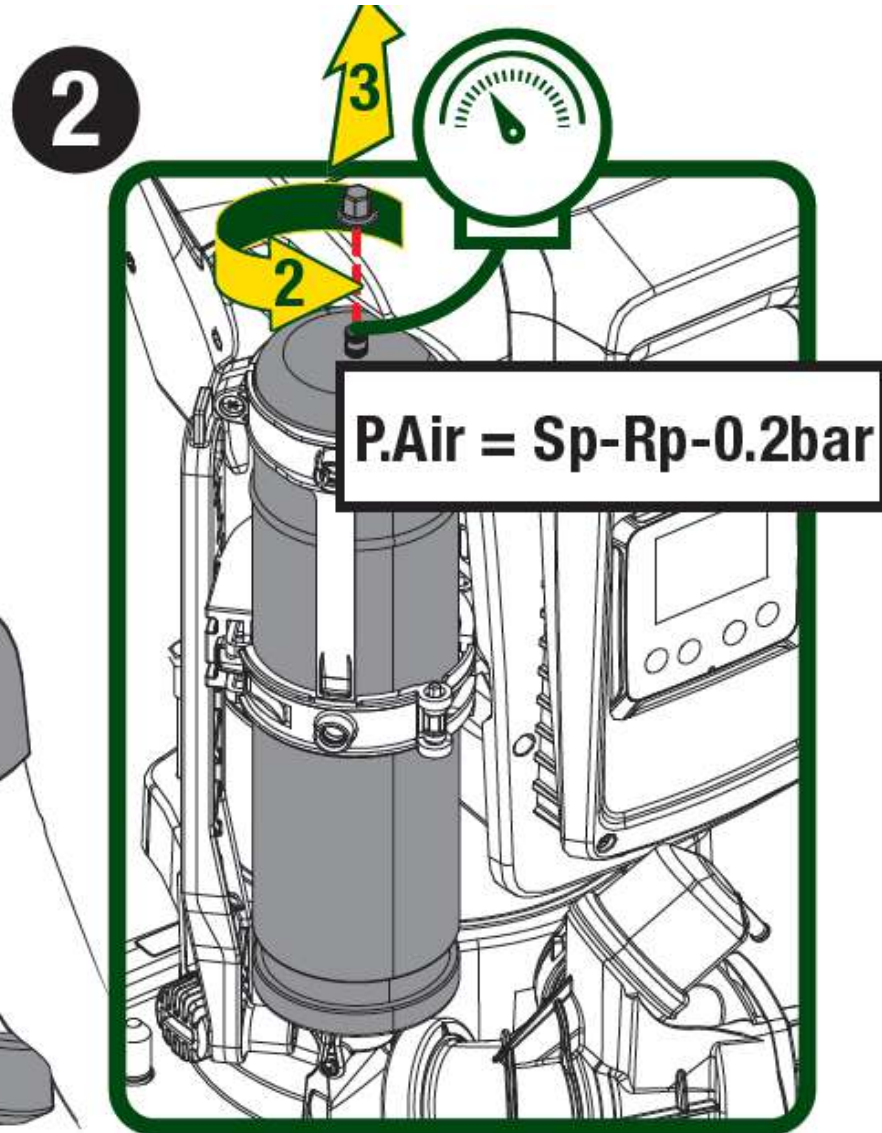
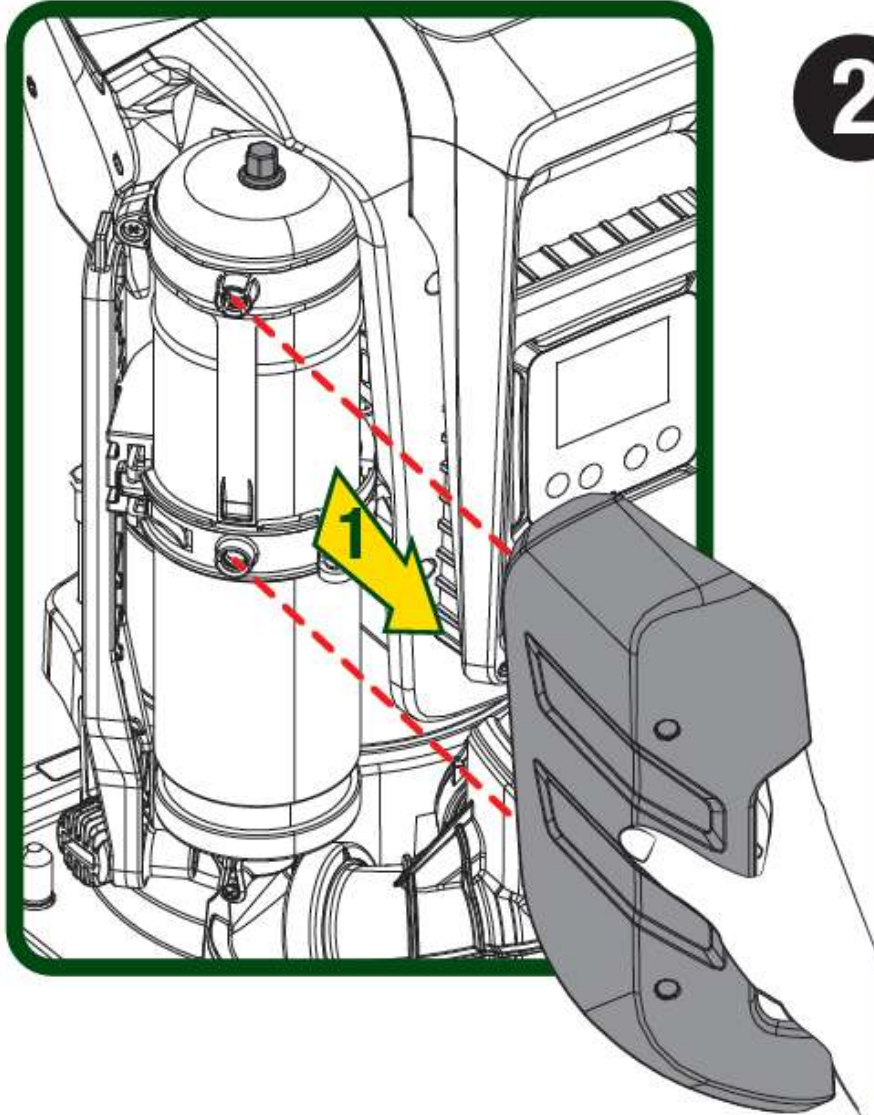

PRIMING THE PUMP

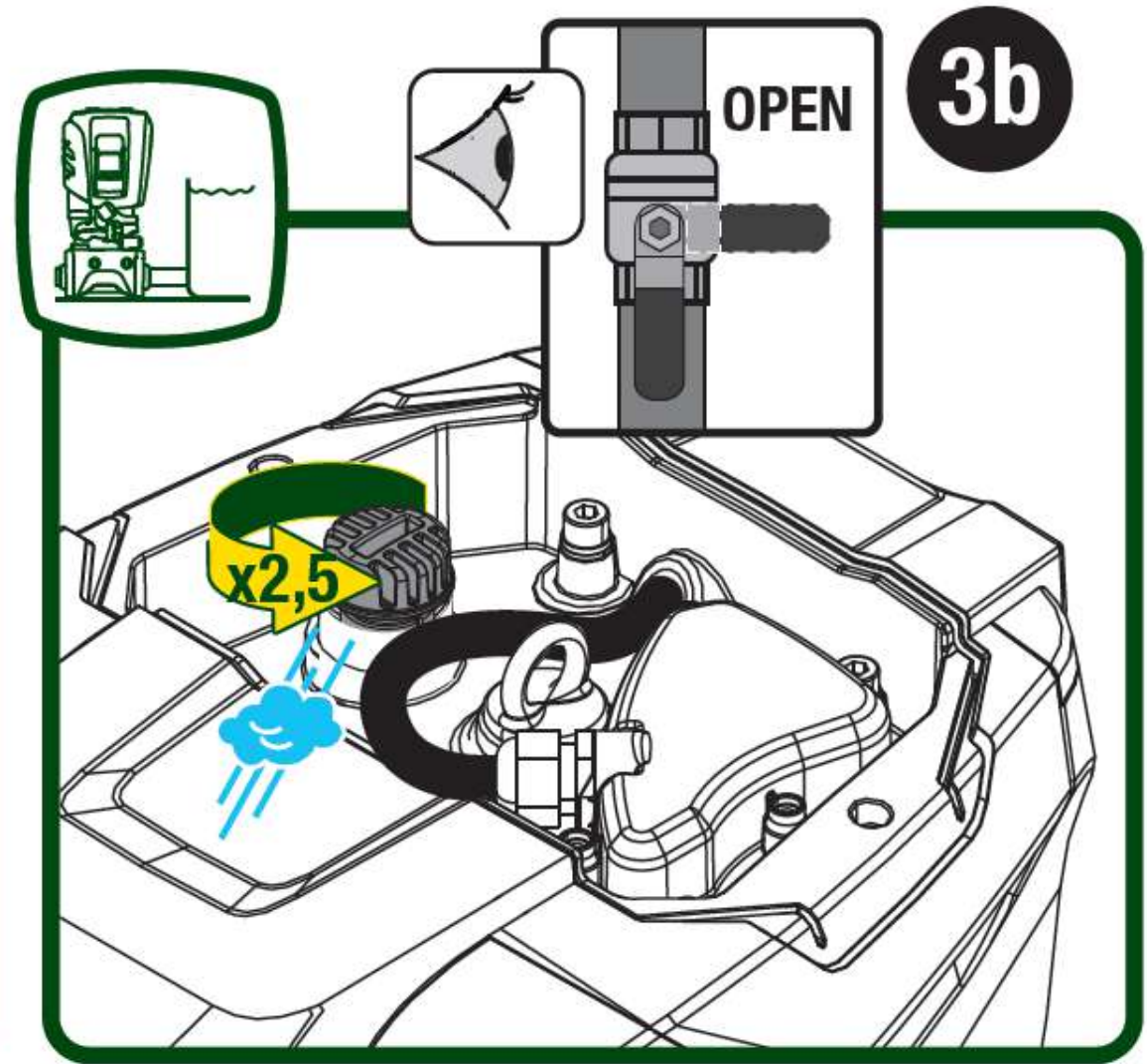
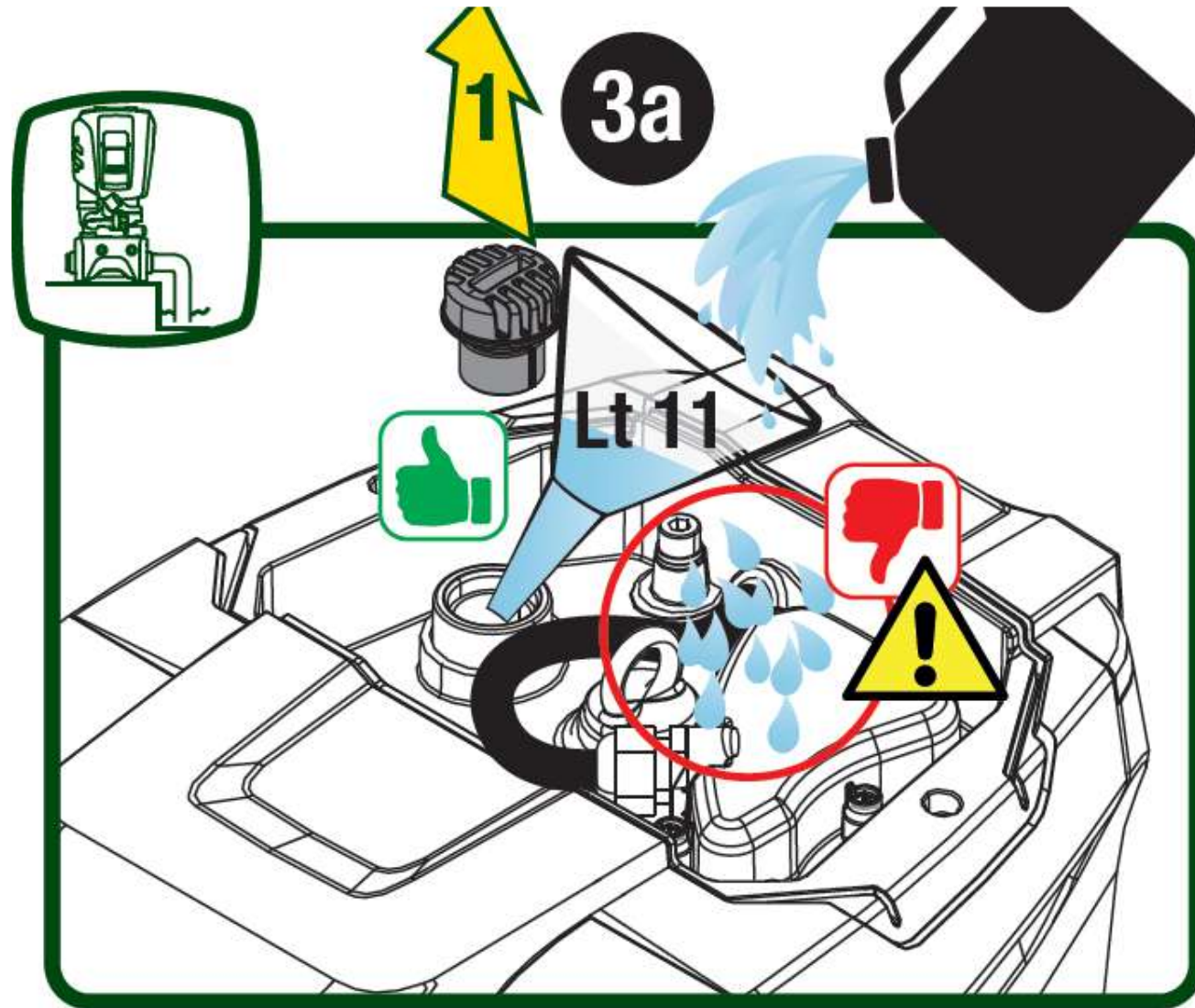

DISPLAY



MENU NAME	DIRECT ACCESS KEYS	HOLD-DOWN TIME
User		On releasing the button
Monitor		2 Sec
Setpoint		2 Sec
Manual		5 Sec
Installer		5 Sec
Technical assistance		5 Sec
Reset factory values		2 sec after switching on appliance
Reset		2 Sec

DISPLAY

<i>Reduced menu (visible)</i>			<i>Extended menu (direct access or password)</i>			
Main Menu	User Menu mode	Monitor Menu set-minus	Setpoint Menu mode-set	Manual Menu set-minus-plus	Installer Menu mode-set-minus	Tech. Assist. Menu mode-set-plus
MAIN (Main Page)	STATUS	BK Back lighting	SP Setpoint pressure	STATUS	RP Decrease pressure for restart	TB Block time for water lack
Menu Selection	RS Revs per minute	TK Backlighting switch-on time		RI Speed setting	OD Type of plant	T1 Low pressure delay
	VP Pressure	LA Language		VP Pressure	AD Address Configuration	T2 Delay in switching off
	VF Display of flow	TE Heat sink temperature		VF Display of flow	MS Measuring system	GP Proportional gain
	PO Power absorbed by pump	BT Card temperature		PO Power delivered to the pump	AS Wireless devices	GI Integral gain
	C1 Pump phase current			C1 Pump phase current	PR Remote pressure sensor	RM Maximum speed
	TE Heat sink temperature			RS Revs per minute	EK Low pressure function on suction	NA Active devices
	Pin Pressure at intake			TE Heat sink temperature	PK Low pressure threshold on suction	NC Max. simultaneous devices

BOOSTER SETS

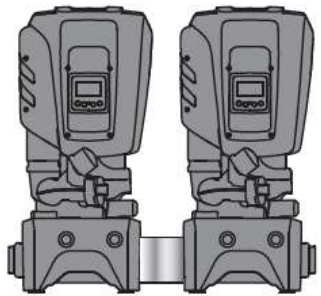

D/A → **NC= 2**
D/S → **NC= 1**

D = DUTY
A = ASSIST
S = STANDBY

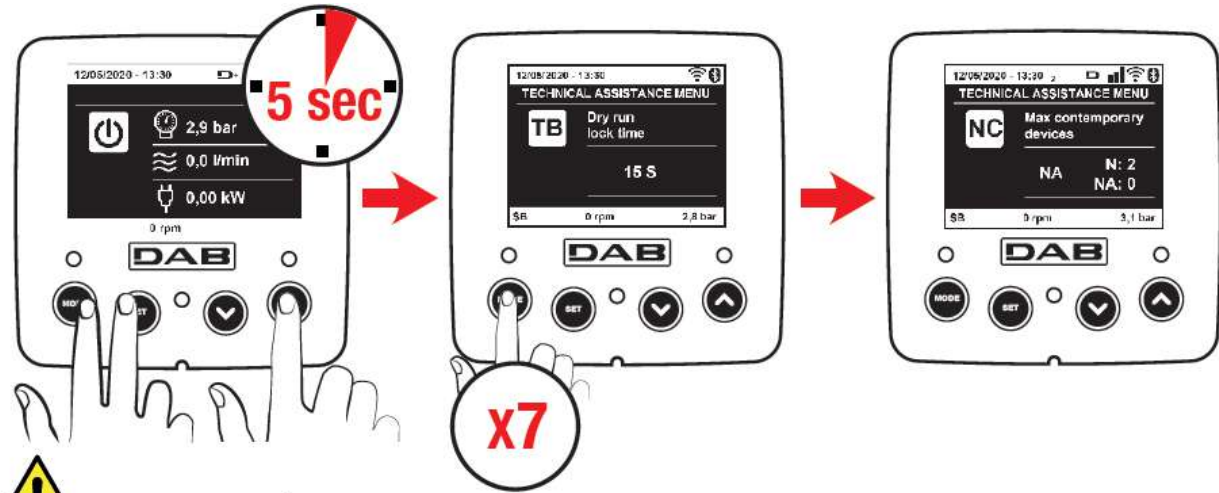

! ACCESSORY

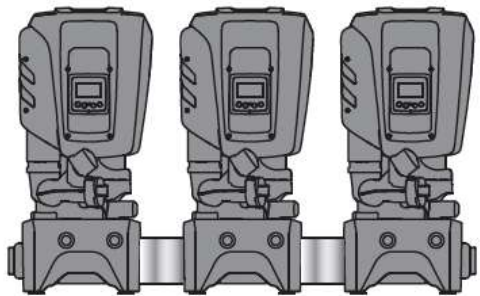

D/A/A → **NC= 3**
D/A/S → **NC= 2**

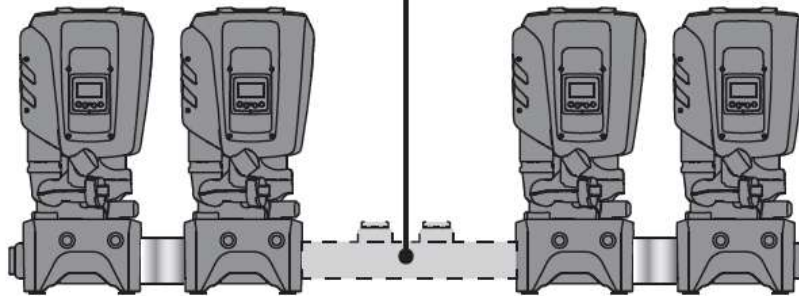

D/A/A/A → **NC= 4**
D/A/A/S → **NC= 3**

BOOSTER SETS



“MODE” and “SET” and “PLUS”
FOR 3 SECONDS
“MODE” TO SCROLL PARAMETERS
ADJUST THE VALUE WITH “+” OR “-”
“SET” TO CONFIRM

WIRELESS

ON BOARD



N

TOTAL NUMBER OF PUMPS

pumps

TOTAL NUMBER OF PUMPS CONNECTED IN THE SAME BOOSTER SET. N IS AUTOMATICALLY DETECTED BY EASYBOX.

NA

ACTIVE PUMPS

1 ... N

TOTAL NUMBER OF PUMPS INVOLVED IN THE PUMPING SYSTEM (ACTIVE + STANDBY + RESERVE)
IF $NA < N$, ONE OR MORE PUMP ARE EXCLUDED: THEY WILL BE CONSIDERED AGAIN ONLY IN CASE OF FAULT ON EASYBOX. DEFAULT: $NA = N$.

NC

SIMULTANEOUS PUMPS

1 ... N

MAX NUMBER OF SIMULTANEOUS OPERATIONAL PUMPS, WHICH SPLIT THE WATER FLOW DEMAND.
IF $NC < NA$, ONE OR MORE PUMP ARE IN STAND-BY. STAND-BY PUMPS CICLICALLY ENTER INTO OPERATION (FUNCTION ROTATION). DEAFULT: $NC = NA$.

IC

RESERVE PUMPS

1 or 2

ANY SINGLE PUMP CAN BE CONFIGURED AS ACTIVE (IC = 1) OR RESERVE (IC = 2). WHEN A PUMP IS SET TO RESERVE, IT IS THE LOWEST IN FUNCTION PRIORITY. DEFAULT: IC = 1.

ET

EXCHANGE TIME

10s ... 9h

EXCHANGE TIME TO BALANCE THE OPERATIONAL TIME BETWEEN THE DIFFERENT PUMPS OF THE BOOSTER SET. EXCHANGE CAN HAPPEN ON STAND-BY OR DURING OPERATION. IF $ET = 0$, AT ANY START A NEW PUMP IS FUNCTIONING. DEFAULT: 2 HOURS.



Networking

Wireless Communication

ESy I/O



extension
module



ESY I&O

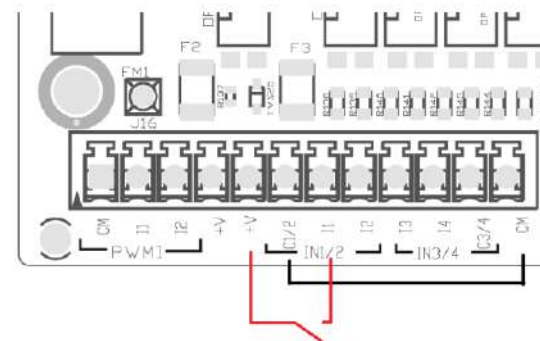
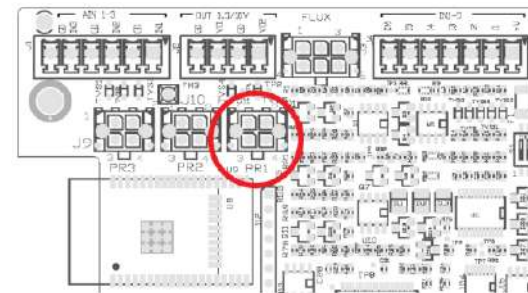
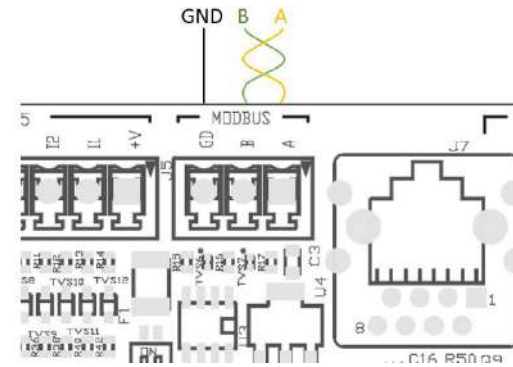
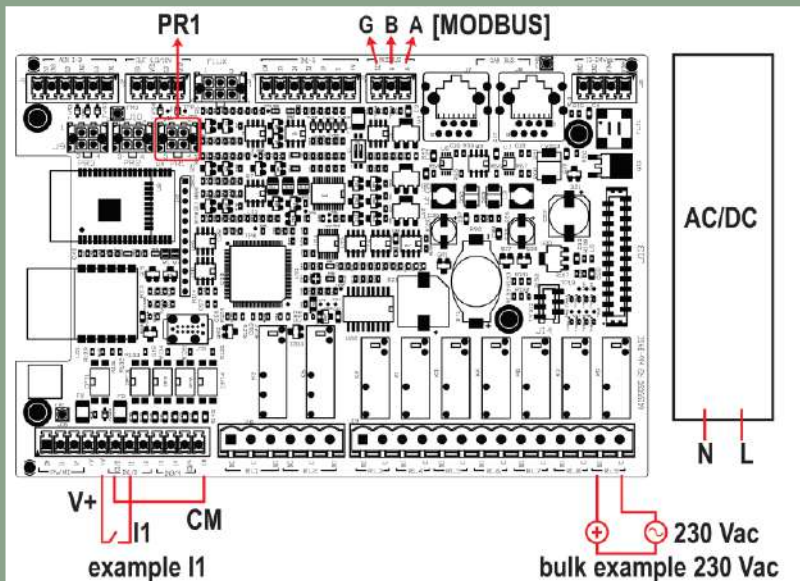

Serial Communication
MODBUS RS485

Additional Set-Point
PRESSURE SENSORS HUBA

Inputs / outputs
DIGITAL CONTACTS

PROTECTION PANELS



Electrical breaker panels are available as accessory for 2/3 pump sets.

The panels are supplied with a mains power lead and a feeding cable for each pump.

They can be delivered together with a support pillar kit, that's fixed on the stainless steel manifolds of the dock.



www.dabpumps.com

